

Second Nature

CO₂

Capable of Making a Difference.

SECND
NATURE

CO₂ Technology

Second Nature systems that utilize CO₂ technology offer several distinct advantages over traditional DX refrigeration systems. These CO₂ sub-critical systems deliver superior refrigeration performance with enhanced sustainability, reduced refrigerant charge requirements and greatly reduced refrigerant leak rates. Simply, they are the most energy-efficient and environmentally-friendly refrigeration systems available in the industry today.

What Exactly is a Sub-Critical System?

Second Nature CO₂ systems operate at pressures similar to standard air conditioning units that use R-410A refrigerant. While those pressures are higher than the ones found in conventional DX systems with HFCs, they are still significantly lower than the critical CO₂ pressure of 1050 psig. As a comparison, transcritical CO₂ systems operate above critical pressure, often approaching 1500 psig.

More than 50 Second Nature CO₂ systems have been installed since 2006. From as far south as Columbia, South America to as far north as Calgary, Canada, in the moderate climates of California to the heat and humidity of Texas, Hill PHOENIX CO₂ systems perform.

- SNLT2 Projects
- SNLTX2 & SNMT2LX Projects

CO₂ Technology Benefits at a Glance:

- Significant HFC charge reduction
- HFC leaks reduced dramatically
- Lower return gas temperatures improve compressor energy performance
- Copper pipe usage reduced (smaller diameters and shorter runs)
- Excellent material compatibility
- Eliminates future refrigerant retrofits that interrupt sales floor activity
- CO₂ refrigerant is abundantly available and inexpensive
- Much smaller carbon footprint
- CO₂ is naturally occurring and delivers a GWP (Global Warming Potential) of almost 0
- Overall energy consumption is less
- Sustainable technology helps achieve GreenChill certification

Hill PHOENIX
E X C E L L E N C E
A DOVER COMPANY



SNLT2 – CO₂ Low Temperature Secondary Coolant Technology

SNLT2 Systems utilize CO₂ as the heat transfer fluid in a secondary coolant system. Since CO₂ has excellent thermodynamic and transport properties, the CO₂ secondary coolant removes heat from low temperature display cases and walk-in freezers via copper piping that is significantly smaller than what is typically required in traditional, direct expansion (DX) systems.

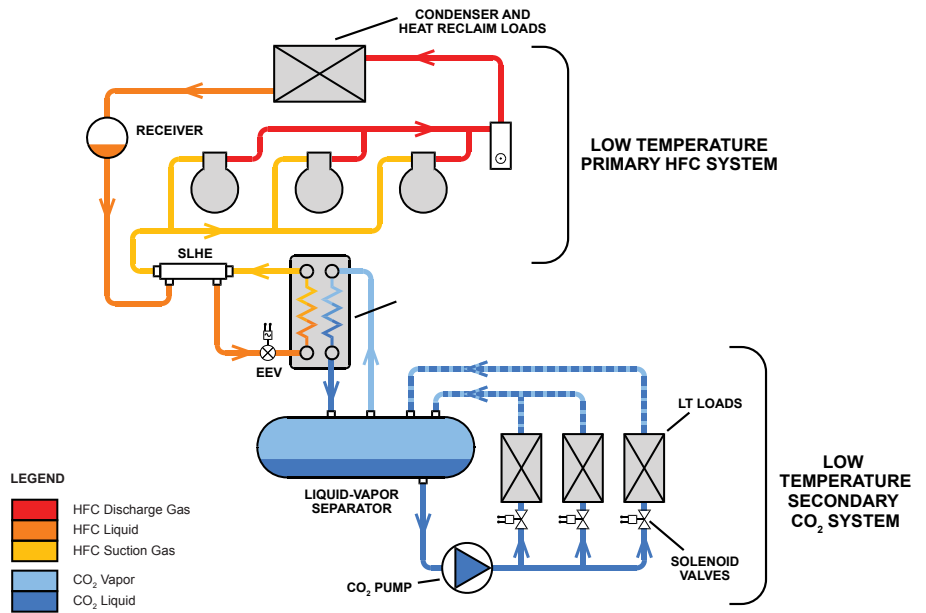

SNMT2 – CO₂ Medium Temperature Secondary Coolant Technology

SNMT2 systems use CO₂ as the heat transfer fluid in a secondary coolant system. SNMT2 systems operate exactly like SNLT2 systems but at a temperature suitable for medium temperature refrigeration. SNMT2 systems are a higher efficiency alternative to secondary systems using glycol.

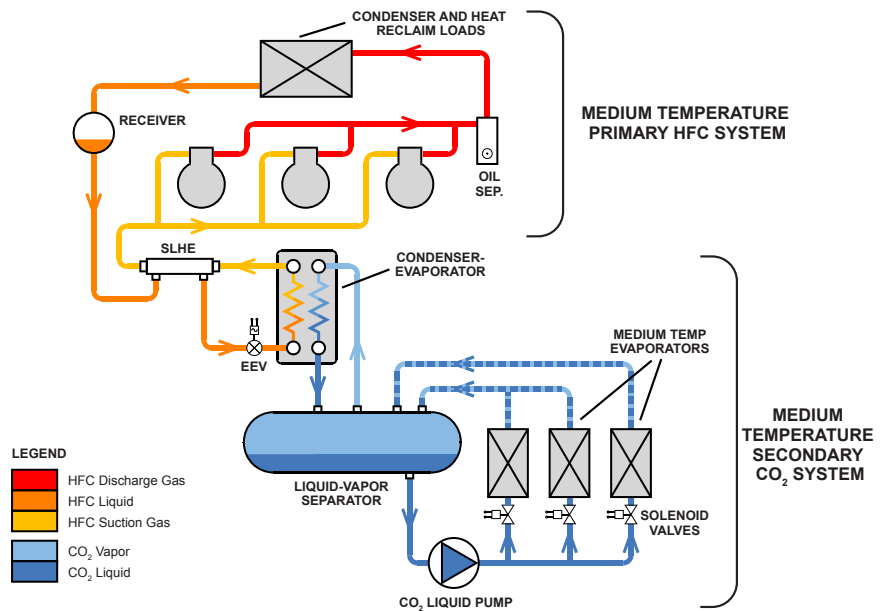

SNLTX2 – CO₂ Direct Expansion Cascade Technology

SNLTX2 systems utilize CO₂ as a low temperature, direct expansion (DX) refrigerant in a cascade system. The CO₂ removes heat from display cases and walk-in freezers via copper piping that is also significantly smaller than what is typically required in traditional HFC-based, direct expansion systems and even smaller than in our SNLT2 secondary systems. The upper cascade (primary system) is a medium temperature refrigeration system.

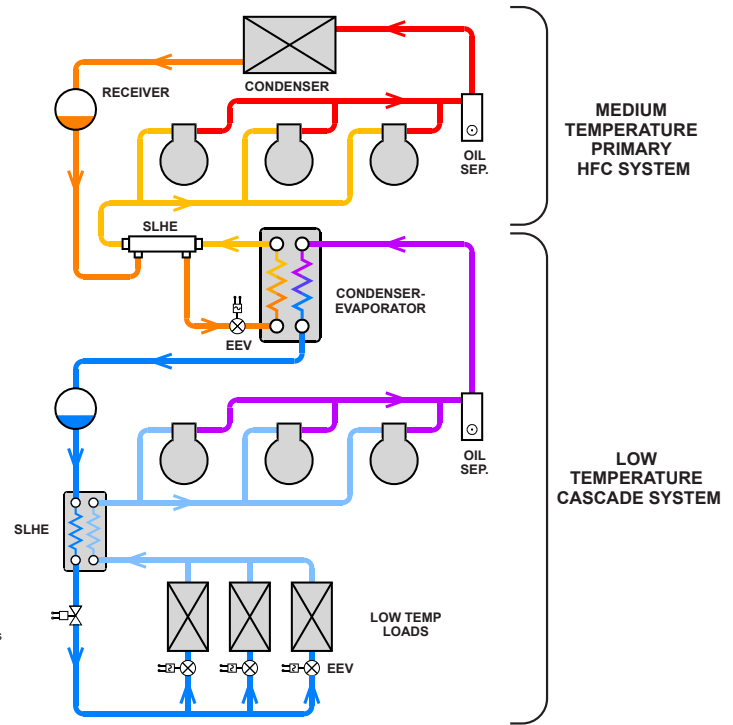
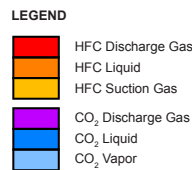

Comparison: SNLT2 vs. SNLTX2

SNLT2 Secondary System

- Pumped-liquid system with simple solenoid valve for evaporator control (same for SNMT2)
- Fully-flooded coils make most use of coil surface
- No superheat section in coils for slightly more efficient evaporator performance than SNLTX2 system
- Able to take full advantage of deep subcooling (30°F liquid) on HFC primary system. Using 30°F liquid can result in energy performance equal to SNLTX2 systems
- Over 30 sites in operation since 2006
- Requires electric defrost
- Little or no circuit balancing required
- Installation of piping critical

SNLTX2 DX Cascade System

- Direct expansion system with components and controls more familiar to contractors/operators
- Hill PHOENIX SmartValve™ system for most economical application of electronic expansion valves
- Direct expansion operation less sensitive to coil circuiting - easier to apply third party coils (cases)
- CO₂ discharge gas desuperheater can be used to improve energy performance
- Smaller line sizes than SNLT2 system and reduced insulation requirements for installed cost savings
- Smaller footprint and lower weight than SNLT2 system
- Lower CO₂ charge than SNLT2 system
- HFC primary system (upper cascade) can be used to cool other medium temperature loads for overall reduced refrigerant charge
- More than 15 sites in operation since 2008
- Requires electric defrost



CO₂ Cascade Technologies

SNLTX2 & SNMT –

CO₂ Cascade Combined with Glycol Secondary

Since the SNLTX2 technology operates with a medium temperature upper cascade, it can be combined with the primary side of our SNMT medium temperature secondary system using glycol. By consolidating the two systems, the required refrigerant charge is further reduced. With more than 600 installations throughout North America, our performance-proven SNMT systems can now be applied with our latest low temperature technologies.

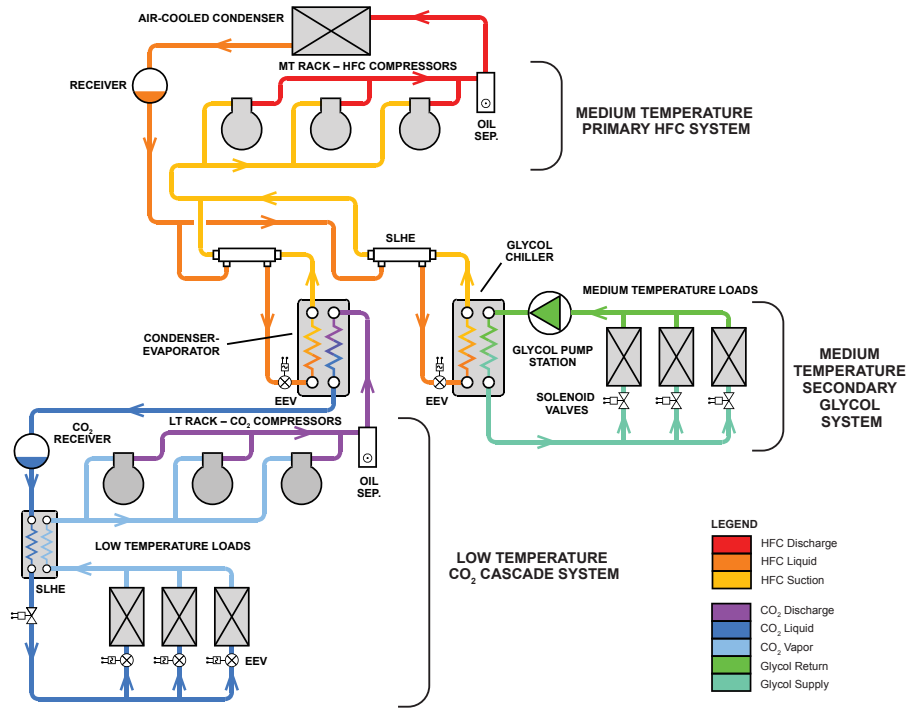

SNMT2LX – CO₂ Combined System Technology

Sharing a common, medium temperature primary system, the SNMT2LX system combines a CO₂ medium temperature secondary system (SNMT2) with a CO₂ low temperature cascade system (SNLTX2) to further reduce refrigerant charge and consolidate duplicate components. Evaporator control uses Hill PHOENIX SmartValve™ technology with electronic expansion valves (EEV) on low temperature and simple solenoid valve control on medium temperature.

Hill PHOENIX completes the picture by providing a full range of standard and specialty display cases with evaporators specifically designed to complement each of the Second Nature products discussed above.

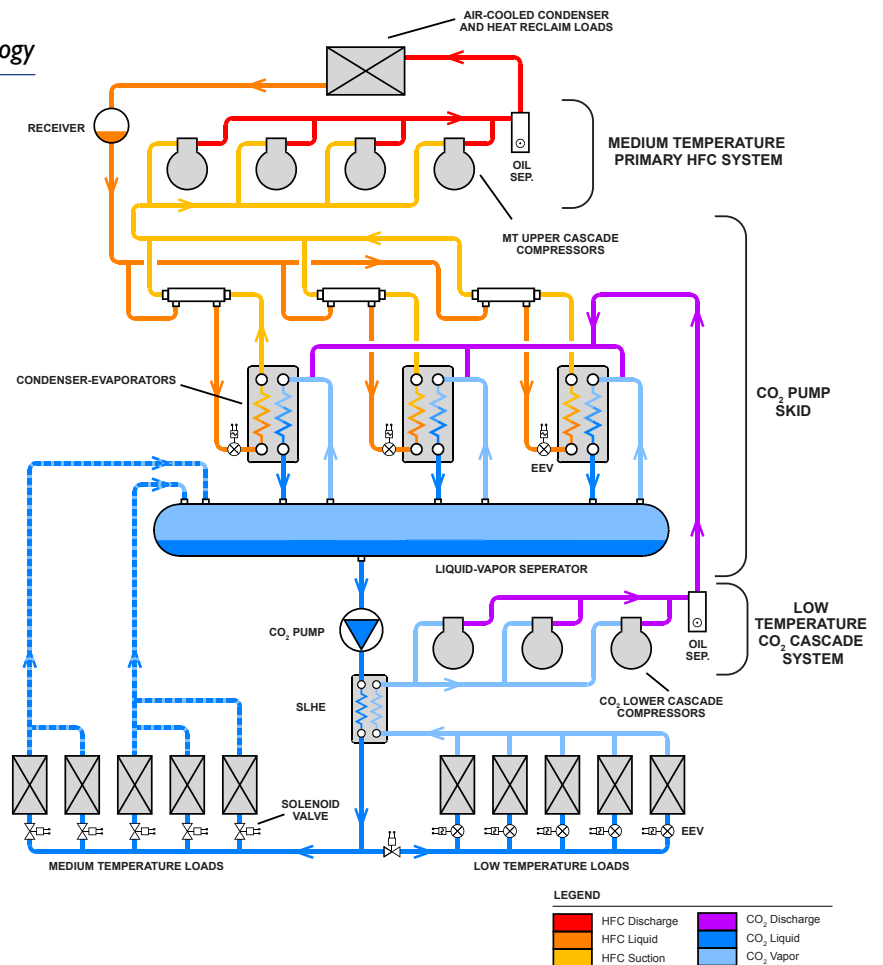



Hill PHOENIX

REFRIGERATION SYSTEMS

709 Sigman Road, Conyers, GA 30013

770-285-3100 phone • 770-285-3071 fax

website: www.hillphoenix.com

e-mail: marketing-refrigerationsystems@hillphoenix.com

Hill PHOENIX
E X C E L L E N C E

A DOVER COMPANY