

High profile prep area generates excitement as employees create meal solutions on the spot. Self-contained mobile case can be positioned anywhere in store.

Utility Prep/Display Case

OSIOPA

Self-Contained Mobile



Hill PHOENIX
DISPLAY CASES

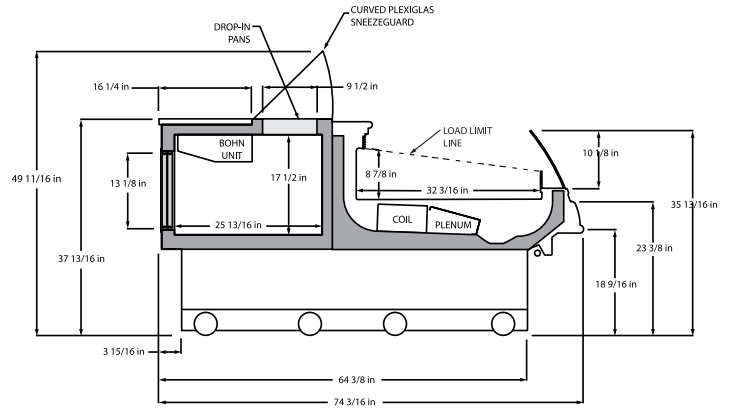
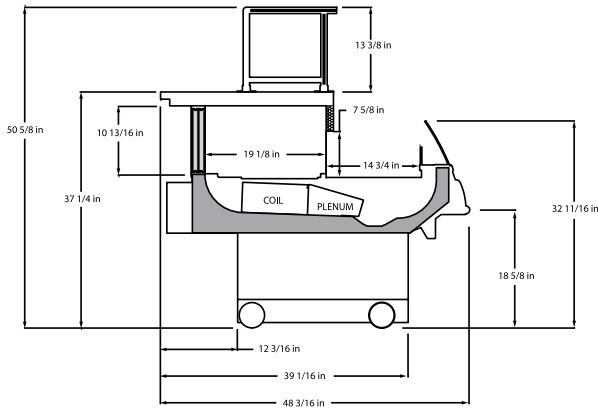

Please consult Hill PHOENIX Engineering Reference Manual for dimensions, plan views and technical specifications. Specifications subject to change without notice. Designed for optimal performance in store environments where temperature and humidity do not exceed 75°F and 55% R.H. Certified to UL 471 and ANSI/NSF Standard 7.



- Merchandiser configured with evaporative drain pan and hose connections, so case can be positioned anywhere in your store.
- ECM energy-efficient fan motors available.

Features and Benefits:

- Unique design ensures uniform case performance and lower average product temperatures with optimum energy efficiency.
- All-steel construction for increased life span and structural integrity.
- Seamless tank liner provides positive drain runoff and enhanced sanitation.
- Integrated two-part polymer bumper system provides unparalleled protection and durability.

Standard Options:

- 5.4 cubic feet of lighted refrigerated storage under prep board holds deli meats, condiments and other items needed for food preparation.
- Customizable condiment pan configuration to meet your prep station requirements.
- Sanalite top provides sturdy cutting surface and is removable for easy cleanup.
- Easy access to front and back of case interior makes cleanup a snap.
- Sneeze guard provides sanitary protection while offering an unobstructed view of prep area.
- Lower front panel available in either a louvered or perforated grille to meet your aesthetic preference.
- Self-contained condensing unit within the base uses environmentally-friendly R134-A refrigerant, eliminating field piping for self-cooling mobility.
- Durable castors lock to hold merchandiser in place and roll freely for easy repositioning.



Hill PHOENIX

DISPLAY CASES

1925 Ruffin Mill Rd., Colonial Heights, VA 23834

804-526-4455 phone • 804-526-2804 fax

website: www.hillphoenix.com

e-mail: marketing-case@hillphoenix.com