

Extra-tall merchandiser maximizes your profits with more vertical facings and greater product capacity of other high red meat cases on the market.

## High Multi-Deck Meat Case

OHHMH

Now Available with New Synerg-E™ Technology



**Hill PHOENIX**  
DISPLAY CASES

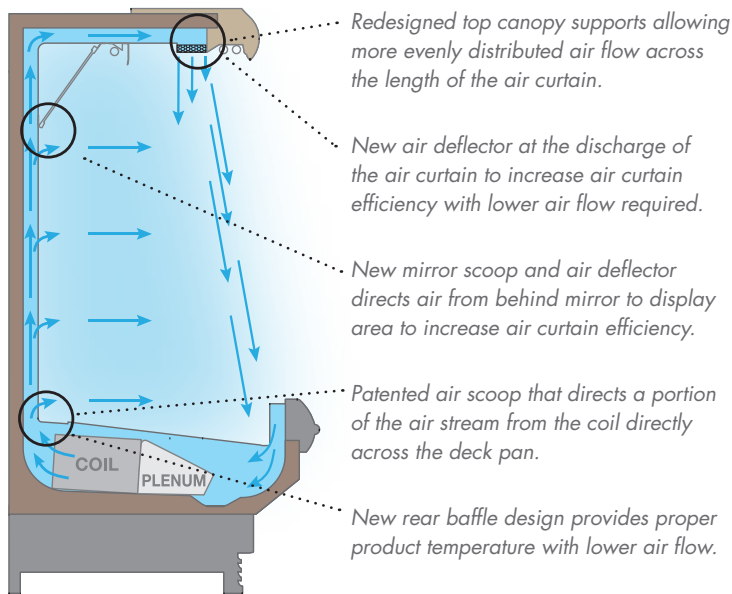

Synerg-E technology delivers un-matched energy efficiency without compromising the integrity of the perishable products being displayed.

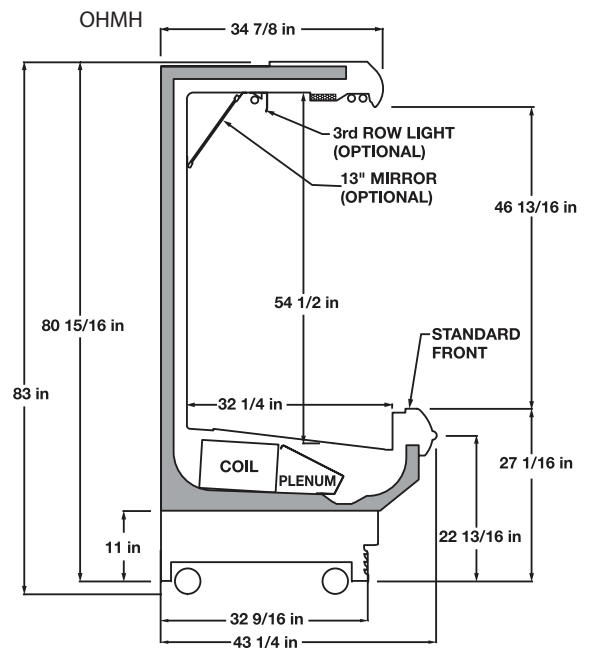

Please consult Hill PHOENIX Engineering Reference Manual for dimensions, plan views and technical specifications. Specifications subject to change without notice. Designed for optimal performance in store environments where temperature and humidity do not exceed 75°F and 55% R.H. Certified to UL 471 and ANSI/NSF Standard 7.

### Energy Options:

- Synerg-E™ Technology with NRGcoil™. Meets DOE 2012 requirements.
- Clearvoyant™ LED Lighting System.
- Exclusive SmartValve™ energy-saving technology available.
- ECM energy-efficient fan motors available.

### Standard Options:

- Three lengths available: 6', 8' and 12'.
- Four front sill heights available for desired product application or merchandising format.
- Configure with a variety of front panel design options, including Standard ORIGIN<sup>2</sup>, Classic Hybrid, Classic Metal or Flat.
- Full-view, solid or square ends available with various interior finishes.
- Variety of cornice lighting choices available for spectacular illumination of product.
- Available shelf sizes: 10", 12", 14", 16", 18" and 20".
- Epoxy-coated wire or plexiglass package stops maintain attractive shelf displays.
- Angled mirrors in 9" or 13" heights.
- Standard off cycle defrost for cost-effective operation; electric, hot gas and reverse air defrost also available.
- Environmentally-friendly Second Nature® secondary coolant application available.

### Features and Benefits:

- Unique design ensures uniform case performance and lower average product temperatures with optimum energy efficiency.
- All-steel construction for increased life span and structural integrity.
- Seamless tank liner provides positive drain runoff and enhanced sanitation.
- Bottom-mounted copper coil and lift-up fan plenum with easily-removable fan basket and motor assembly for ease of maintenance.
- Integrated, two-part polymer bumper systems provide unparalleled protection and durability.
- Removable castors for easy merchandiser unloading, movement and placement.
- Meets DOE 2012 requirements with the Synerg-E Technology option.



**Hill PHOENIX**  
DISPLAY CASES

1925 Ruffin Mill Rd., Colonial Heights, VA 23834  
804-526-4455 phone • 804-526-2804 fax  
website: www.hillphoenix.com  
e-mail: marketing-case@hillphoenix.com