

Locate within service departments to provide customers with self-service convenience and full-service personal attention.

Single Deck Utility Case

OUM

Now Available with New Synerg-E™ Technology
(Narrow Version ONUM Shown)



Hill PHOENIX
DISPLAY CASES

OUM-NRG

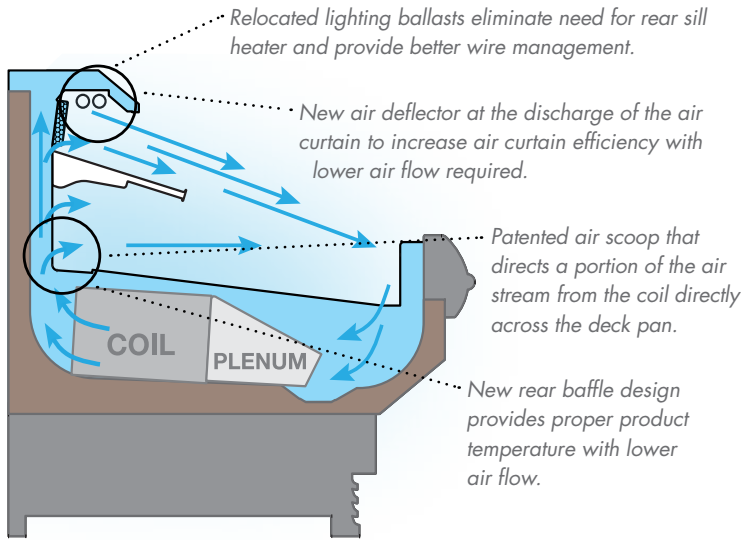

Synerg-E technology delivers un-matched energy efficiency without compromising the integrity of the perishable products being displayed.

OUM/ONUM

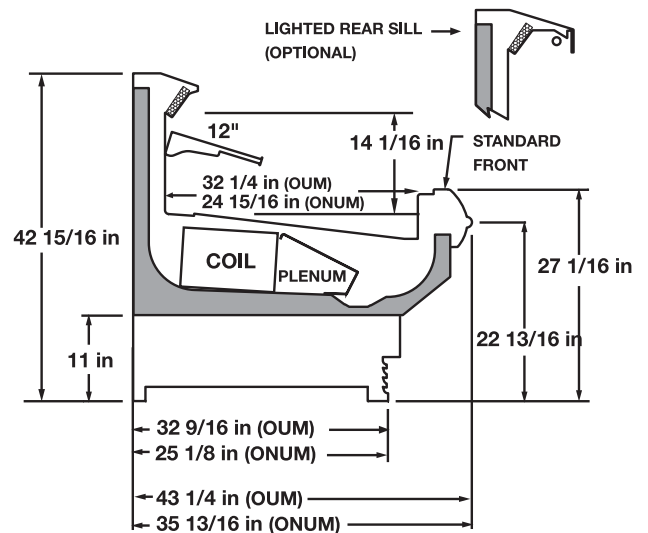

Please consult Hill PHOENIX Engineering Reference Manual for dimensions, plan views and technical specifications. Specifications subject to change without notice. Designed for optimal performance in store environments where temperature and humidity do not exceed 75°F and 55% R.H. Certified to UL 471 and ANSI/NSF Standard 7.

Model OUM/ONUM

SINGLE DECK UTILITY CASE

Energy Options:

- Synerg-E™ Technology with NRGcoil™. Meets DOE 2012 requirements.
- Clearvoyant™ LED Lighting System.
- Exclusive SmartValve™ energy-saving technology available.
- ECM energy-efficient fan motors available.

Standard Options:

- Four lengths available: 4', 6', 8' and 12'.
- Two depths - OUM & ONUM.
- Configure with a variety of front panel design options, including Standard ORIGIN², Classic Hybrid, Classic Metal, and Flat Front.
- Choose from a variety of front sill and base frame heights.
- Match the ONUM with its hot foods counterpart, the ONUH, to create exciting food service possibilities.
- Configure with solid or full-view ends.
- Optional rear sill lighting provides additional illumination for product display.
- Available with lighted or unlighted adjustable shelves in depths from 10" to 16".
- Optional tag moulding accommodates pricing and POS materials.
- Standard off cycle defrost for cost-effective operation; electric, hot gas and reverse air defrost also available.
- Environmentally-friendly Second Nature® secondary coolant application available.

Features and Benefits:

- Unique design ensures uniform case performance and lower average product temperatures with optimum energy efficiency.
- All-steel construction for increased life span and structural integrity.
- Seamless tank liner provides positive drain runoff and enhanced sanitation.
- Bottom-mounted copper coil and lift-up fan plenum with easily-removable fan basket and motor assembly for ease of maintenance.
- Integrated, two-part polymer bumper systems provide unparalleled protection and durability.
- Removable castors for easy merchandiser unloading, movement and placement.
- Meets DOE 2012 requirements with the Synerg-E Technology option.



Hill PHOENIX

DISPLAY CASES

1925 Ruffin Mill Rd., Colonial Heights, VA 23834
 804-526-4455 phone • 804-526-2804 fax
 website: www.hillphoenix.com
 e-mail: marketing-case@hillphoenix.com