

This efficient merchandiser is available in standard and narrow depths and can be configured to display dairy, deli, beverages and floral.

Glass Door Reach-In

ORB

*Medium Temperature Case -
Optimum Energy-Efficiency*



Hill PHOENIX
DISPLAY CASES

ORB

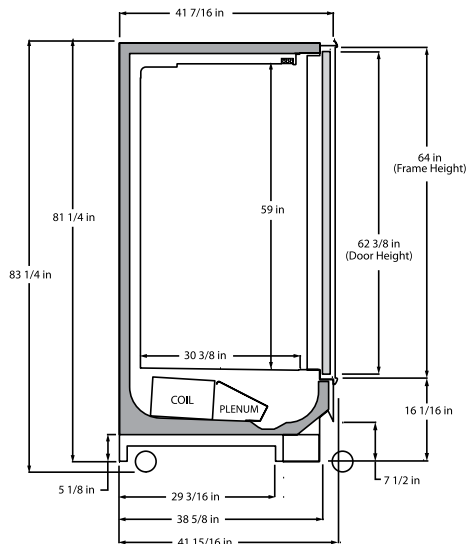

ORBH

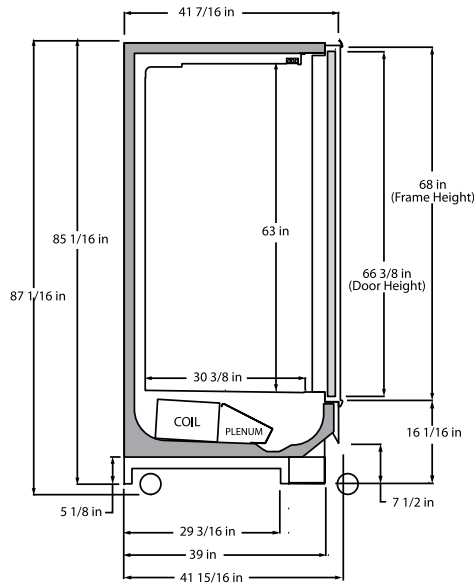

Streamlyne Bumper Option

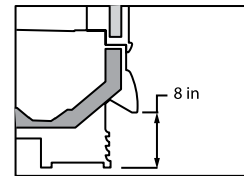

Classic Hybrid Bumper Option

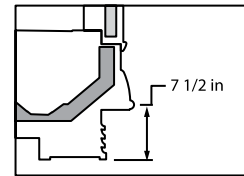

Please consult Hill PHOENIX Engineering Reference Manual for dimensions, plan views and technical specifications. Specifications subject to change without notice. Designed for optimal performance in store environments where temperature and humidity do not exceed 75°F and 55% R.H. Certified to UL 471 and ANSI/NSF Standard 7.

Standard Options:

- Available in 2-, 3-, 4-, 5- and 6-door models.
- Also available in 8' (32" doors) and 12' (36" doors) lengths.
- Available extra-tall model (ORBH), a taller version of our popular ORB, with all the same great functions and features.
- Innovative LED lighting option increases visual impact of product while reducing energy consumption and released heat in case.
- Glass door finishes available in polished aluminum, silver satin or black. Custom colors available.
- Available shelf sizes: Wire - 16", 18", 20", 22" and 23-1/2"; Solid - 18", 20", 22", 24" and 27". Top shelf must be 24" or less when using 27" shelves. (Recommended configuration is one 24" top shelf and four 27" shelves below top shelf.)
- Bottom wire rack and plexiglass or wire package stops available.
- Optional Streamlyne or Classic Hybrid integrated bumper systems provide additional protection and durability.
- Polymer and metal end trim available.
- ECM energy-efficient fan motors available.
- Standard off cycle defrost for cost-effective operation; electric and hot gas defrost also available.
- Exclusive SmartValve™ energy-saving technology available.
- Environmentally-friendly Second Nature® secondary coolant technology available.

Features and Benefits:

- Great merchandising with exceptional energy performance.
- Unique design ensures uniform case performance and lower average product temperatures with optimum energy efficiency.
- All-steel construction for increased life span and structural integrity.
- Seamless tank liner provides positive drain runoff and enhanced sanitation.
- Bottom-mounted copper coil and lift-up fan plenum with easily-removable fan basket and motor assembly for ease of maintenance.
- Removable castors for easy merchandiser unloading, movement and placement.



Hill PHOENIX

DISPLAY CASES

1925 Ruffin Mill Rd., Colonial Heights, VA 23834

804-526-4455 phone • 804-526-2804 fax

website: www.hillphoenix.com

e-mail: marketing-case@hillphoenix.com