

Unitized, multi-deck island case  
with faceted end caps; a great  
utility merchandiser.

## Unitized Multi-Deck Island Case

O3UM/O3EIF

Now Available with new  
Synerg-E™ Technology



**Hill PHOENIX**  
DISPLAY CASES

## O3UM-NRG/O3EIF-NRG

Relocated lighting ballasts eliminate need for rear sill heater and provide better wire management.

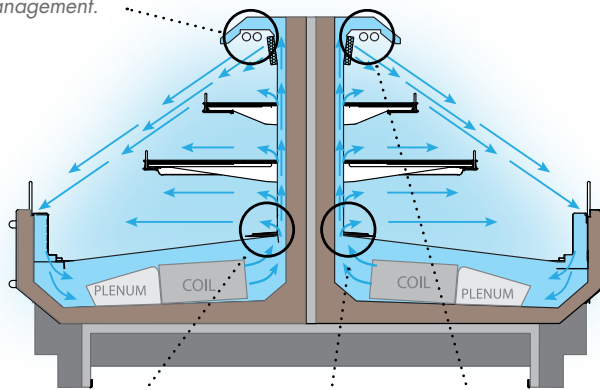

Patented air scoop that directs a portion of the air stream from the coil directly across the deck pan.

New air deflector at the discharge of the air curtain to increase air curtain efficiency with lower air flow required.

New rear baffle design provides proper product temperature with lower air flow.

## O3UM/O3EIF

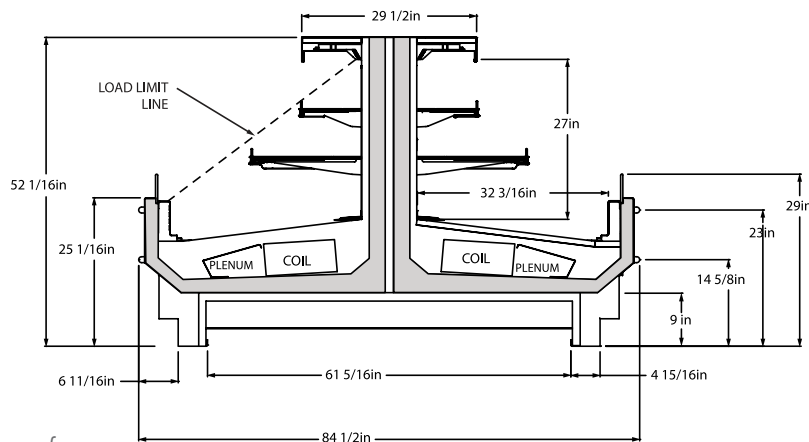

Please consult Hill PHOENIX Engineering Reference Manual for dimensions, plan views and technical specifications. Specifications subject to change without notice. Designed for optimal performance in store environments where temperature and humidity do not exceed 75°F and 55% R.H. Certified to UL 471 and ANSI/NSF Standard 7.

### Energy Options:

- Synerg-E™ Technology with NRGcoil™. Meets DOE 2012 requirements.
- Clearvoyant™ LED Lighting System.
- Exclusive SmartValve™ energy-saving technology available.
- ECM energy-efficient fan motors available.

### Standard Options:

- Choose from a variety of available lengths based on our O3UM model options.
- Choose from a variety of exterior design options or have our Specialty Products group design something customized to your needs.
- Optional rear sill lighting provides additional illumination for product display.
- Available with lighted or unlighted adjustable shelves in depths from 10" to 18".
- Optional tag moulding accommodates pricing and POS materials.
- Optional electrical outlets in kickplate available.
- Standard off cycle defrost for cost-effective operation; electric, hot gas and reverse air defrost also available.
- Environmentally-friendly Second Nature® secondary coolant application available.

### Features and Benefits:

- Unique design ensures uniform case performance and lower average product temperatures with optimum energy efficiency.
- All-steel construction for increased life span and structural integrity.
- Each case designed with seamless tank liner providing positive drain runoff and enhanced sanitation.
- Multiple units seamlessly joined together cut down on installation costs with single-point utility connections.
- Removable castors for easy merchandiser unloading, movement and placement.



**Hill PHOENIX**

DISPLAY CASES

1925 Ruffin Mill Rd., Colonial Heights, VA 23834

804-526-4455 phone • 804-526-2804 fax

website: [www.hillphoenix.com](http://www.hillphoenix.com)

e-mail: [marketing-case@hillphoenix.com](mailto:marketing-case@hillphoenix.com)