

Versatile island merchandiser is available in wide and narrow depths. Low center sill height of 40" adds an open, airy feel and great departmental visibility.

Single Deck Island Case

OIM

Superior Visibility and Easy Access to Meat, Deli, Cheese, Bakery and Grab-n-Go Items



Hill PHOENIX
DISPLAY CASES

ONIM Shown

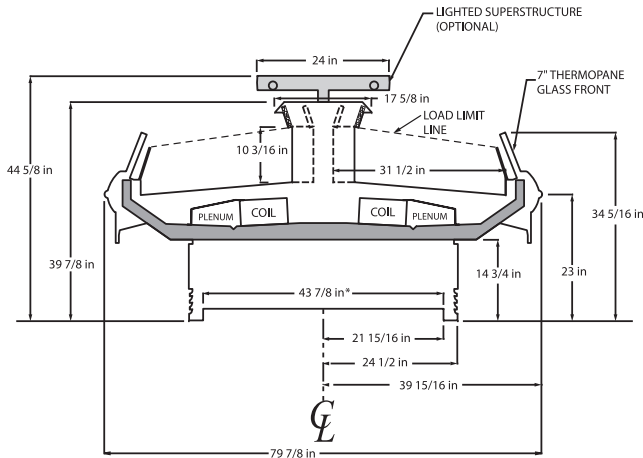

Please consult Hill PHOENIX Engineering Reference Manual for dimensions, plan views and technical specifications. Specifications subject to change without notice. Designed for optimal performance in store environments where temperature and humidity do not exceed 75°F and 55% R.H. Certified to UL 471 and ANSI/NSF Standard 7.

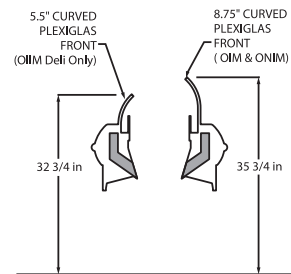
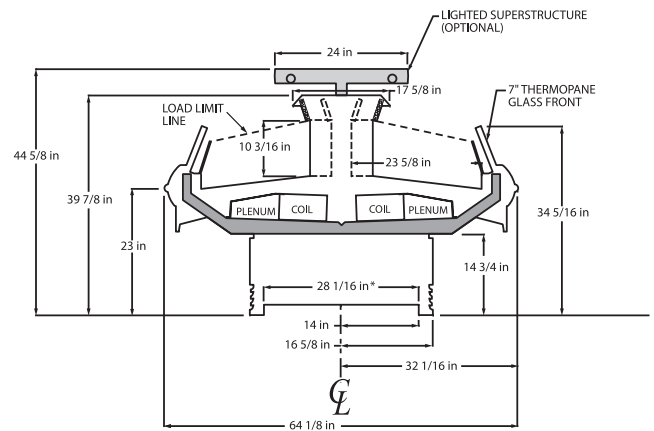

Standard Options:

- Two double wraparound merchandiser lengths (8' and 12') available.
- ONIM is 16" slimmer than our OIM model. A great merchandiser for small spaces or aisles adding flexibility and merchandising creativity.
- Self-contained options available.
- Single-joint ends available - OIMB 6', 8' and 12' and ONIMB 8' and 12' lengths.
- Double-joint ends available - OIMBB 8' lengths.
- Island design offers generous 14.75" non-refrigerated display area under the sills for solution-based merchandising.
- Optional tower superstructure (24" x 45", with or without lights) offers extra space for impulse merchandising or for arranging eye-catching seasonal displays.
- Optional 5.5" curved Plexiglas, 8" thermopane or 8.75" curved Plexiglas sills available.
- Optional front bumper tag moulding to accommodate pricing and POS material.
- Adjustable wire display racks with multiple rear wall and front wall positions.
- Optional electrical outlet can be installed in end kickplate for easy power access.
- ECM energy-efficient fan motors available.
- Standard off cycle defrost for cost-effective operation; electric or hot gas defrost also available.
- Exclusive SmartValve™ energy-saving technology available.
- Environmentally-friendly Second Nature® secondary coolant application available.

Features and Benefits:

- Unique design ensures uniform case performance and lower average product temperatures with optimum energy efficiency.
- All-steel construction for increased life span and structural integrity.
- Seamless tank liner provides positive drain runoff and enhanced sanitation.
- Integrated two-part polymer bumper systems provide unparalleled protection and durability.
- Removable castors for easy merchandiser unloading, movement and placement.



Hill PHOENIX

DISPLAY CASES

1925 Ruffin Mill Rd., Colonial Heights, VA 23834

804-526-4455 phone • 804-526-2804 fax

website: www.hillphoenix.com

e-mail: marketing-case@hillphoenix.com