

This narrow-depth merchandiser displays the same quantity of product facings as our OHM while reducing required product stock.

Narrow Multi-Deck Meat Case

ONHM

Now Available with New Synerg-E™ Technology



Hill PHOENIX
DISPLAY CASES

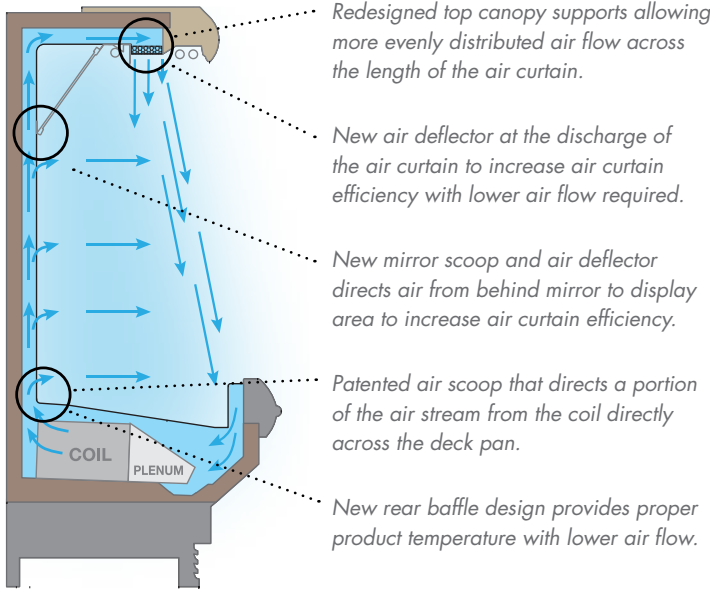

Redesigned top canopy supports allowing more evenly distributed air flow across the length of the air curtain.

New air deflector at the discharge of the air curtain to increase air curtain efficiency with lower air flow required.

New mirror scoop and air deflector directs air from behind mirror to display area to increase air curtain efficiency.

Patented air scoop that directs a portion of the air stream from the coil directly across the deck pan.

New rear baffle design provides proper product temperature with lower air flow.

Synerg-E technology delivers un-matched energy efficiency without compromising the integrity of the perishable products being displayed.

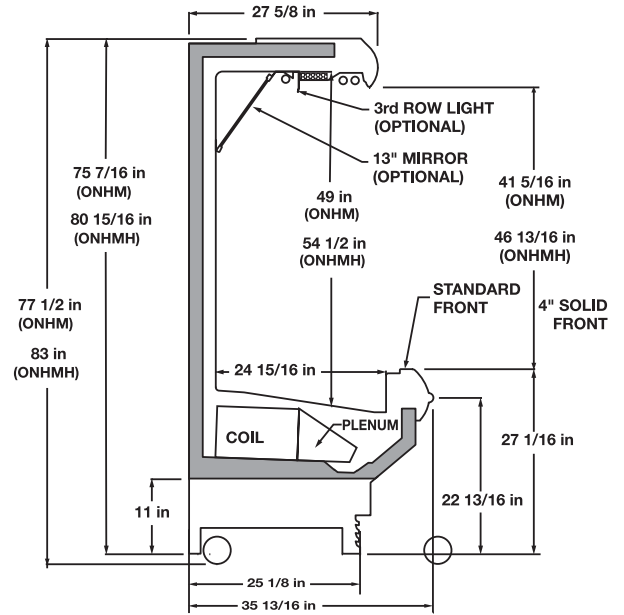

Please consult Hill PHOENIX Engineering Reference Manual for dimensions, plan views and technical specifications. Specifications subject to change without notice. Designed for optimal performance in store environments where temperature and humidity do not exceed 75°F and 55% R.H. Certified to UL 471 and ANSI/NSF Standard 7.

ONHM is 8" narrower than our popular OHM, with all the same great functions and features. Also available, ONHMH extra-tall, narrow merchandiser, provides more vertical facings and greater product capacity in a narrow footprint.

Energy Options:

- Synerg-E™ Technology with NRGcoil™. Meets DOE 2012 requirements.
- Clearvoyant™ LED Lighting System.
- Exclusive SmartValve™ energy-saving technology available.
- ECM energy-efficient fan motors available.

Standard Options:

- Four lengths available: 4', 6', 8' and 12'.
- Configure with a variety of front panel design options, including Standard ORIGIN®, Classic Hybrid, Classic Metal, and Flat Front.
- Full-view, solid or square ends available with various interior finishes.
- Variety of cornice lighting choices available, including incandescent and LED for spectacular illumination of product.
- Available with adjustable solid shelves in depths from 10" to 20", with or without lights, and in a variety of finishes.
- Epoxy-coated wire or plexiglass package stops maintain attractive shelf displays.
- Angled mirrors in 9" or 13" heights.
- Standard off cycle defrost for cost-effective operation; electric, hot gas and reverse air defrost also available.
- Environmentally-friendly Second Nature® secondary coolant application available.

Features and Benefits:

- Unique design ensures uniform case performance and lower average product temperatures with optimum energy efficiency.
- All-steel construction for increased life span and structural integrity.
- Seamless tank liner provides positive drain runoff and enhanced sanitation.
- Bottom-mounted copper coil and lift-up fan plenum with easily-removable fan basket and motor assembly for ease of maintenance.
- Integrated, two-part polymer bumper systems provide unparalleled protection and durability.
- Removable castors for easy merchandiser unloading, movement and placement.
- Meets DOE 2012 requirements with the Synerg-E Technology option.



Hill PHOENIX

DISPLAY CASES

1925 Ruffin Mill Rd., Colonial Heights, VA 23834

804-526-4455 phone • 804-526-2804 fax

website: www.hillphoenix.com

e-mail: marketing-case@hillphoenix.com