

Generate significant display impact with extra-wide glass doors. Great product visibility. Outstanding merchandiser for beverages, dairy, deli, fresh meat and floral.

High Multi-Deck Reach-In

6RBLH

Medium Temperature Floral Case - Tall/Wide Doors - Superior Display Opportunities



Hill PHOENIX
DISPLAY CASES

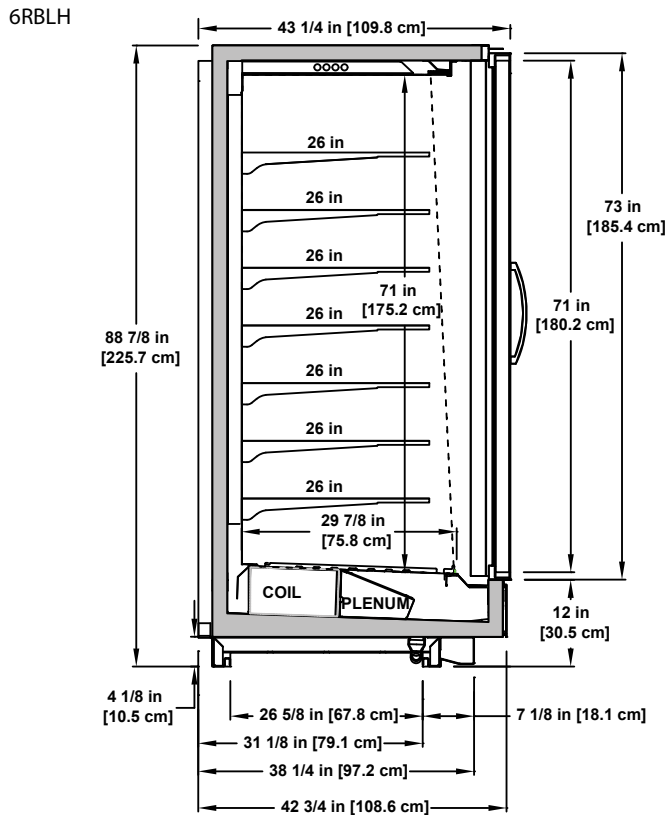

Please consult Hill PHOENIX Engineering Reference Manual for dimensions, plan views and technical specifications. Specifications subject to change without notice. Designed for optimal performance in store environments where temperature and humidity do not exceed 75°F and 55% R.H. Certified to UL 471 and ANSI/NSF Standard 7.

Standard Options:

- Available Door Configurations and Widths:
2-, 3-, 4- and 5-door case lengths: 30" door width
8' case length, 3-door configuration: 32" door width
8' case length, 4-door configuration: 24" door width
12' case length, 4-door configuration: 36" door width
12' case length, 6-door configuration: 24" door width
- Innovative LED lighting options increase visual impact of product while reducing energy consumption and released heat in case.
- Glass door finishes available in polished aluminum, silver satin or black. Custom colors available.
- Available with narrow-profile, single or double (French style) doors without center mullion.
- Available shelf sizes: Wire Shelves – 16", 18", 20", 22" and 23 1/2"; Solid Shelves – 18", 20", 22", 24" and 26".
- Bottom wire rack and plexiglass or wire package stops available.
- Solid, full view glass, and super-view ends with polymer or metal end trim available.
- Standard off cycle defrost for cost-effective operation; electric defrost also available.
- Exclusive SmartValve™ energy-saving technology available.
- Environmentally-friendly Second Nature® secondary coolant technology available.

Features and Benefits:

- Design ensures uniform case temperature performance at optimum energy efficiency.
- ECM energy-efficient fan motors standard.
- Larger door sizes provide better product visibility.
- Large throat opening with low front maximizes packout while keeping product within reach of customers.
- All-steel construction for increased life span and structural integrity.
- Seamless tank liner provides positive drain runoff and enhanced sanitation.
- Removable castors for easy merchandiser unloading, movement and placement.



Hill PHOENIX

DISPLAY CASES

1925 Ruffin Mill Rd., Colonial Heights, VA 23834

804-526-4455 phone • 804-526-2804 fax

website: www.hillphoenix.com

e-mail: marketing-case@hillphoenix.com